

Special Topics in Virtual Reality

Display Devices 2/2

<http://tinyurl.com/STVR2019>

Anton L. Fuhrmann
2019



Projection Displays

Anton L. Fuhrmann
2019



Classification of Projection Technology

- Cathod Ray Tubes (CRT)
- Liquid crystal (LCD)
- Micro-Mirrors (DLP)
- Reflective LCD (LCOS, D-ILA)
- exotic and little-used devices (Laser, Eidophor)



CRT Projector

„Cathode Ray Tube“ („Kathodenstrahlröhre“)

- Same technology as classic TV-set
 - Three different tubes (RGB)
 - Analog technology
 - Fast (120Hz-180Hz frame-rate → active stereo)
 - Low luminance (typically 1000 ANSI lm)
 - Good color reproduction
 - Black is really black!
 - Expensive, but extremely good images
- } Difficult to adjust

CRT Projector



Anton L. Fuhrmann
2019

Advanced Topics in VR



CRT Projector

Calibrating them is a lengthy and tedious procedure:

- STEP ONE: VERIFY THE CORRECT SCREEN/PROJECTOR DIMENSIONS
- STEP TWO: VERIFY THE CORRECT SCANNING POLARITY
- STEP THREE: CENTER THE GREEN IMAGE IN THE PICTURE TUBE
- STEP FOUR: CENTER THE GREEN IMAGE ON THE SCREEN
- STEP FIVE: ADJUST THE OPTICAL FOCUS
- STEP SIX: ADJUST THE TUBE "FLAPPING"
- STEP SEVEN: ADJUST THE GREEN REFERENCE IMAGE
- STEP EIGHT: ADJUST THE GREEN REFERENCE IMAGE OVERSCAN
- STEP NINE: MATCH THE RED IMAGE TO THE GREEN REFERENCE
- STEP TEN: MATCH THE BLUE IMAGE TO THE GREEN REFERENCE
- STEP ELEVEN: CENTERING THE USER POSITION CONTROLS

(from a manual)

and then: do it all again for the second projector!

Anton L. Fuhrmann
2019

Advanced Topics in VR



LCD Projector

„Liquid Crystal Display“ („Flüssigkristall“)

- Transmissive LCD panel(s) with lamp
- Slight color-dependent polarization
→ troubles with polarized stereo!
- Mediocre color reproduction (no gamma curve)
- Higher luminance (>1000 ANSI lm)
- only about 50% of panel surface active

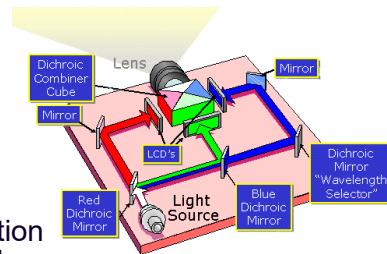

DLP (Micro-Mirror) Projector

„DLP™“ Digital Light Processing
Micro-Mechanical Chips by
Texas Instruments



- about 89% of panel surface active
- but visible pixel structure
- inexpensive, but variable color reproduction

DLP Projector

micro-mechanic:
tiltable mirrors
two positions, switched
by electrostatic force

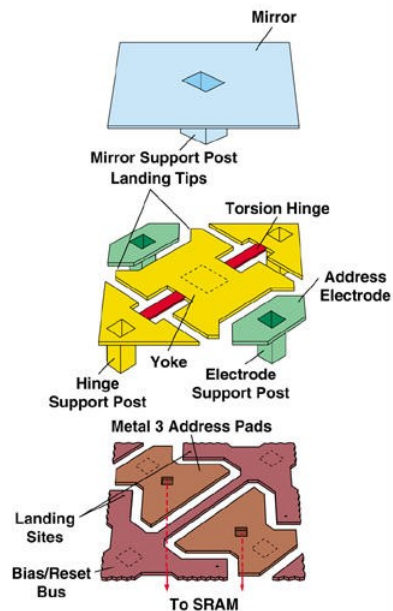

DLP Projector

tiltable mirrors, electron microscopic view

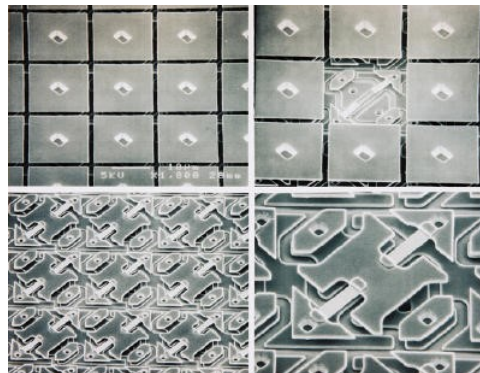

DLP Projector

mirrors produce on/off pattern only
modulate on-to-off ratio to generate grayscale

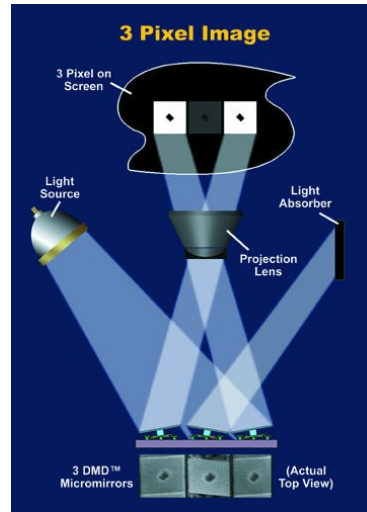

DLP Projector

inexpensive single-chip projectors need color filter wheel to generate colors:

in many cases, these wheels contain „white“ as additional color, thereby significantly enhancing black/white contrast, but impairing color reproduction

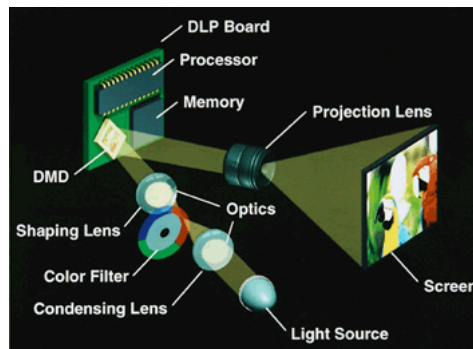

DLP Projector

Only expensive three-chip projectors support faithful color reproduction:

Since micro-mirrors are extremely fast, some of these expensive projectors support output frame rates of >100Hz and thereby active stereo

Examples:

- BARCO Galaxy
- Christie Mirage

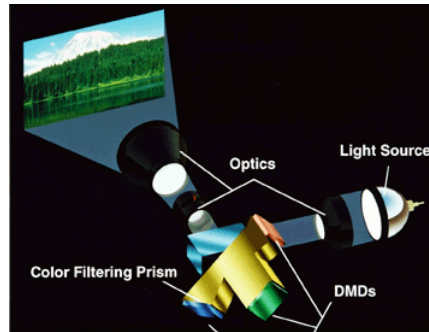

DLP LED/Laser Projector

Use combined LED/Laser light source instead of mercury lamp

Advantage:

- Higher efficiency
- Longer lamp life (~20.000h)
- No color wheel, since LED/Laser can be pulsed

Disadvantage:

- Still not very bright (~3500lm)

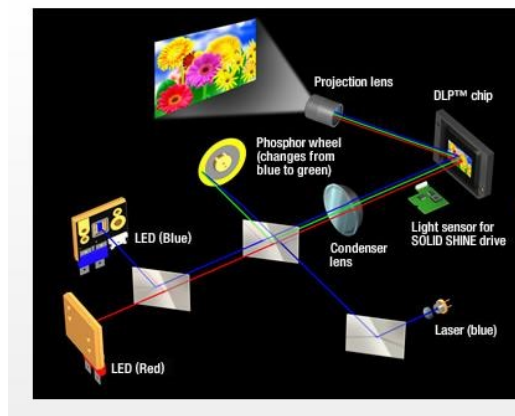

reflective LCD Projector

„LCoS“ Liquid Crystal on Silicon

„D-ILA“ Direct Drive Image Light Amplifier

- high resolutions (up to QXGA, 2048 x 1536)
- almost no pixel structure (93% area usable)
- good colour reproduction
- medium luminance

reflective LCD Projector

The switching elements are placed behind the liquid crystal, so almost no active display area is lost (only 7%)

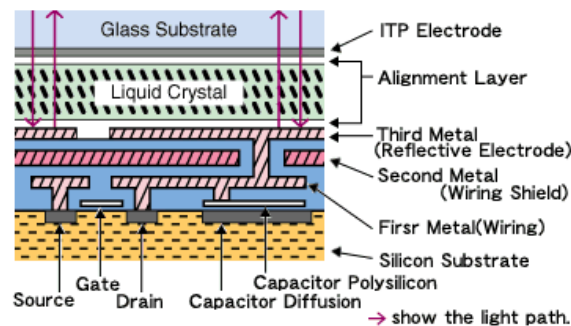

reflective LCD Projector

The light from the lamp is reflected from the surface of the display element:

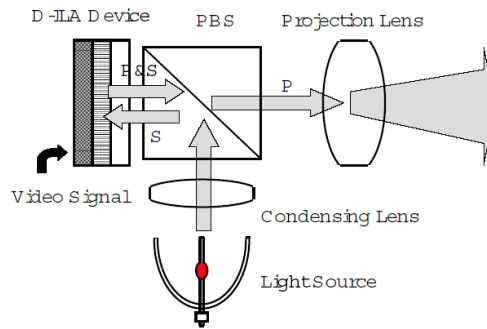

reflective LCD Projector

Using three elements and some prisms, we get color output:

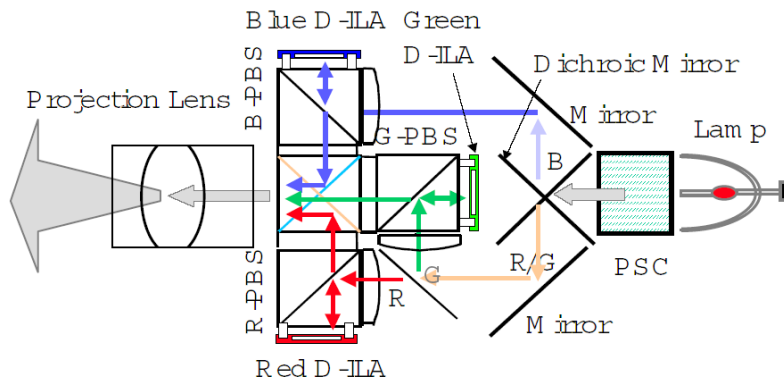

reflective LCD Projector

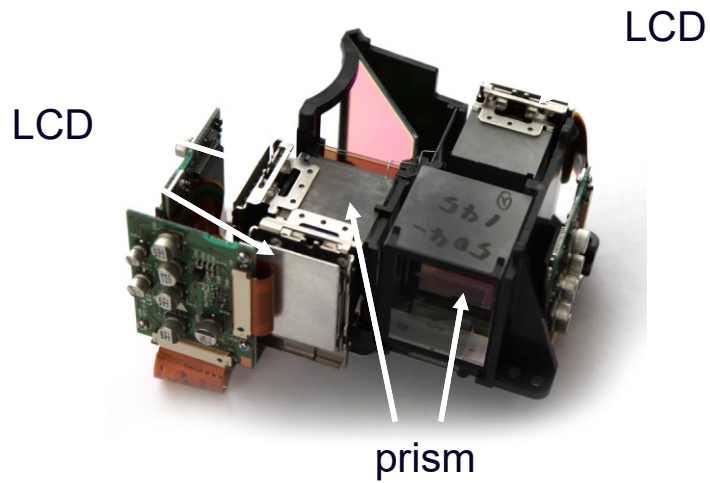

Anton L. Fuhrmann
2019

Advanced Topics in VR



Stereoscopic Display Technologies

Anton L. Fuhrmann
2019



Classification of Stereo Technology

Separation of Left/Right image by

- Space (two displays, parallax display)
- Color (red/green, etc.)
- Time (left after right image, „active“ stereo)
- Plane of Polarization (linear polarized)
- Rotation of Polarization (circular polarized)
- Spectrum (Infitec™)

Parallax Stereo with Lenticulars

Lenticular lenses (cylinders) send different images in different directions.

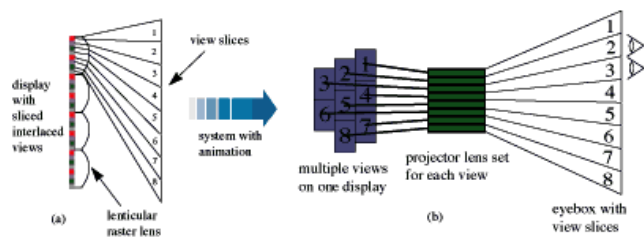

Similar to “3D” postcards and stickers.

Parallax Stereo with Lenticulars

A raster of cylindrical lenses in front of an LCD shows different rows/columns to the users eyes:

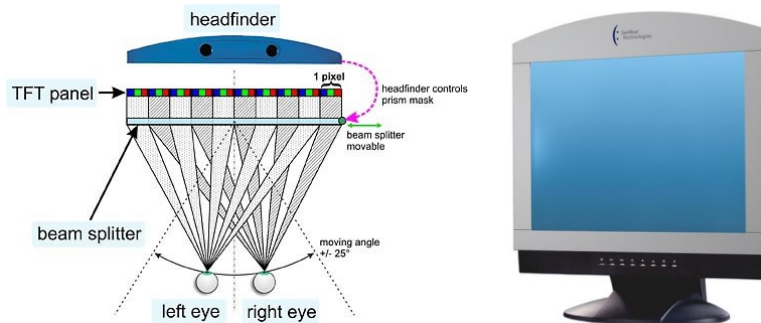

Anton L. Fuhrmann
2019

Advanced Topics in VR



Parallax Barrier

A simple parallax barrier works like this:

A parallax barrier shields a display screen. The distance between screen and barrier, as well as the resolutions of both are calculated to correctly display left pixels (green) only to the left eye and vice versa.

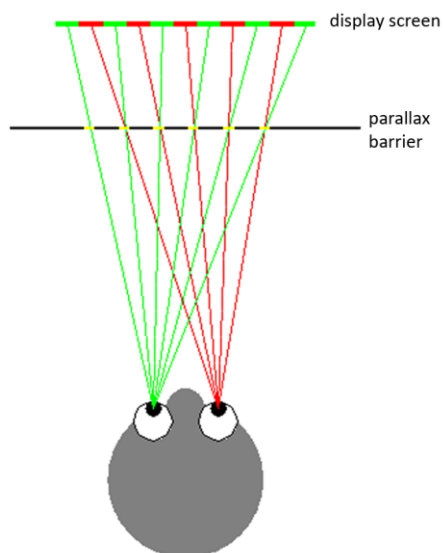

Anton L. Fuhrmann
2019

Advanced Topics in VR



“Looking Glass” Display

LCD/w 45 view slices over 50° FoV (lenticular?)



Anton L. Fuhrmann
2019

Advanced Topics in VR



Slanted Parallax Barrier

A simple approach extremely reduces the horizontal resolution.

Better: treat each LCD-triade as three independent pixels
⇒ “triples” horizontal resolution

use slanted barrier, otherwise one view-slice gets only one primary color!

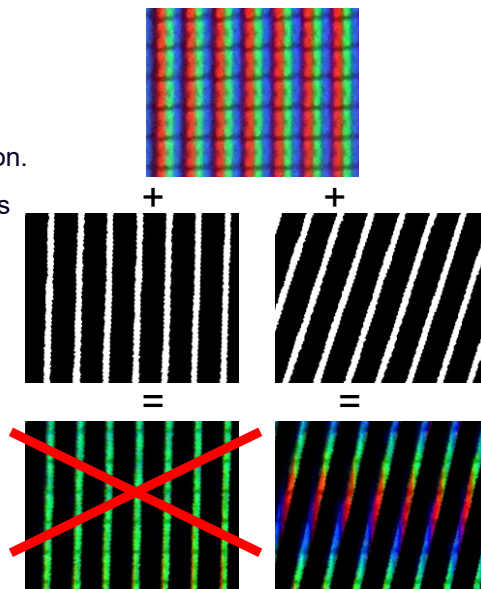

<http://csc.lsu.edu/~kooima/pdfs/Kooima-VR07.pdf>

Anton L. Fuhrmann
2019

Advanced Topics in VR



Slanted Parallax Barrier

Image calculated
for SPB:

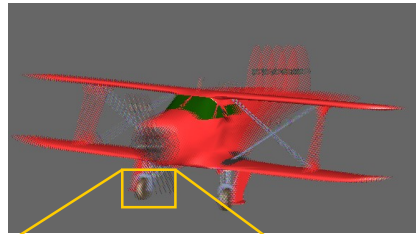

original view detail

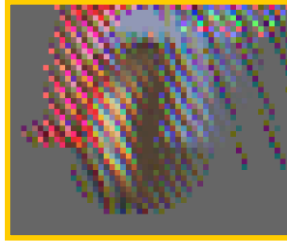
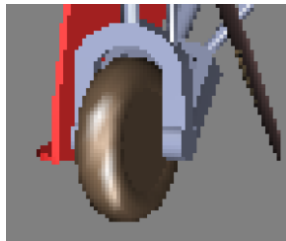

parallax
view
detail

Slanted Parallax Barrier

Advantages vs. simple approach or lenticular lenses:

- “higher” resolution (distributed over vertical resolution too)
- less view-dependent artifacts than lenticulars
- less expensive to manufacture than lenticulars

Disdvantages vs. lenticular lenses:

- lower contrast, since all light not coming through a slot in the barrier is absorbed

Adaptive Parallax Barrier

Ken Perlin built the prototype of a display with adjustable parallax barrier (essentially another vertically striped LCD in front of the display):

<http://mrl.nyu.edu/~perlin/courses/fall98/projects/autostereo.html>

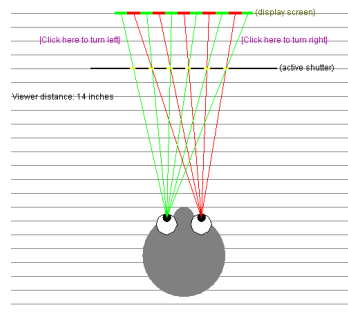

Parallax Stereo

Advantages:

- no glasses
- multi-user, when more than 2 viewing zones

Disadvantages:

- lenticular system exhibits color artifacts
- works in praxis only horizontally
- reduces spatial resolution of display
- mediocre separation

Active Stereo

Means stereo de-multiplexed by „active“ glasses, with electronics:

- time-multiplex: left/right/left/right...
- needs fast display (CRT, DLP)
- needs “active” glasses with shutters, which hide the wrong images → synchronization with source needed!
- works good for back-projection

Active Stereo Devices

infrared emitter



fast display
(monitor or projector)

>100frames/s



pulsed infrared light
sync signal

(RF can also be used)

LCD-shutter
glasses



Barco “BARON”
virtual table
(backprojection with
CRT projector)

Active Stereo Devices

DLP link

works without additional transmitter
modulate the sync signal directly as
an imperceptible flash directly in the
projected image:

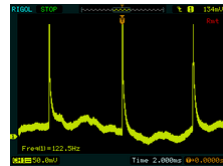

<https://de.wikipedia.org/wiki/Shutter-3D-System#DLP-Link>

Active Stereo Devices

Ultra short throw distance:
DELL s500 / NEC NP-U300x



200cm diagonal
@50cm distance

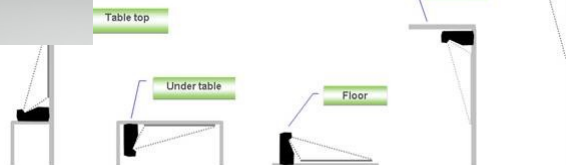

1 DLP projector
resolution : 1280x800
Brightness (Lumens) : 3200 ANSI lm
Full On/Off: 2300:1
Weight: 7 kg
Price : ≈ 900€ !

Ultra Short Throw Projection

Main advantage is that front projection for surround display possible:
(Almost) no shadowing by user compared to "classical" front projection
Better luminance distribution than rear projection (low vignetting)

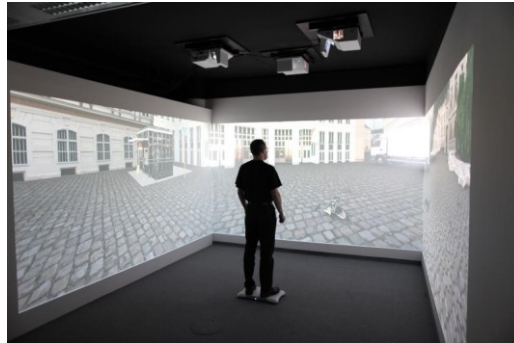

Ultra Short Throw Projection

Main principle: free-form (not spherical!) mirror in beam path:

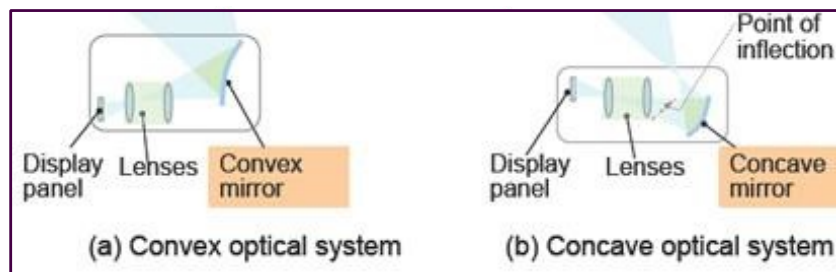

(a) Convex optical system

(b) Concave optical system

© Ricoh

Passive Stereo

Means stereo de-multiplexed by „passive“ glasses, without electronics:

- Color (red/green, etc.)
- Plane of Polarization (linear polarized)
- Rotation of Polarization (circular polarized)
- Spectrum (Infitec™)

Anaglyph Stereo

Multiplexing by using one color for the left eye image and another for the right:

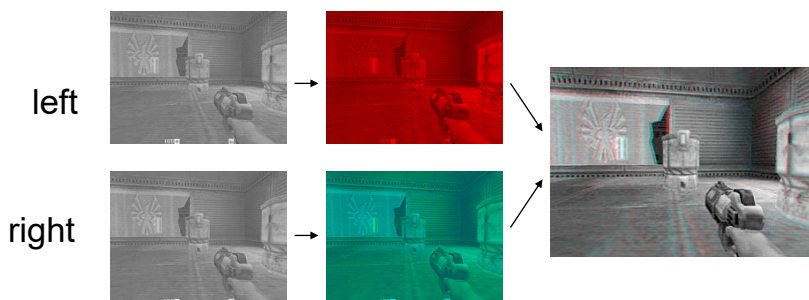

Anaglyph Stereo

Combine color images by replacing the red channel of the right-eye image with the red channel of the left-eye image.

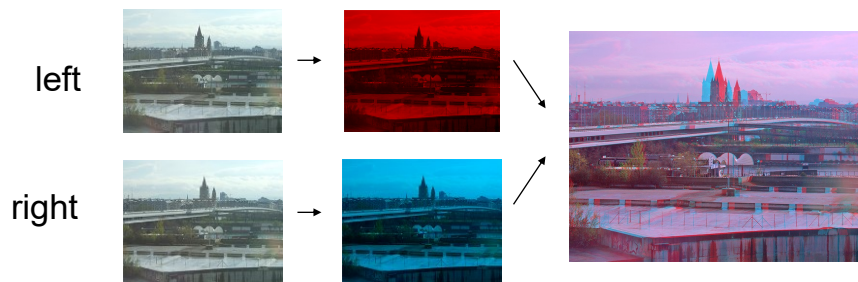

Anaglyph Stereo



Anaglyph Stereo

Advantages:

- fast
- inexpensive
- works on all color media (print, TV, etc.)
- works good on back-projection

Disadvantages:

- mediocre color reproduction

ColorCode 3-D

Multiplexing by „splitting depth and color“
between left & right eye:

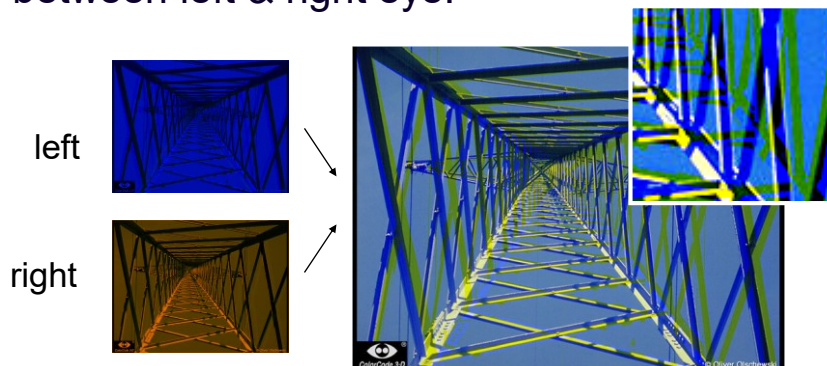

ColorCode 3-D

Advantages:

- fast (use a shader)
- inexpensive
- works on all color media
- works good on back-projection
- displays full color (sort of)

Disadvantages:

- your brain melts (eyestrain, blue filter very dark)

Polarization Stereo

Multiplexing by manipulating the direction of oscillation of the projected light.

Using filters in front of the projector(s) and users eyes, and a special screen:

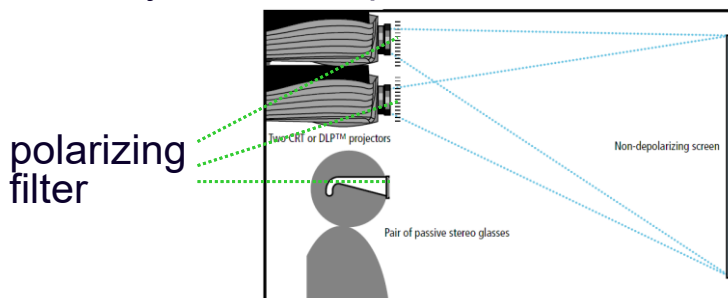

Polarization Stereo

Quality depends on:

filters:

- how much “correct” light is transmitted (R→R, L→L)
- how much “incorrect” light is transmitted (L→R, R→L)

screen:

- how much polarization is destroyed?
(back-projection screens are worse, except for specially designed, hard screens)

Polarization Types

Normal light oscillates in many directions

Linear polarized light oscillates only in one plane

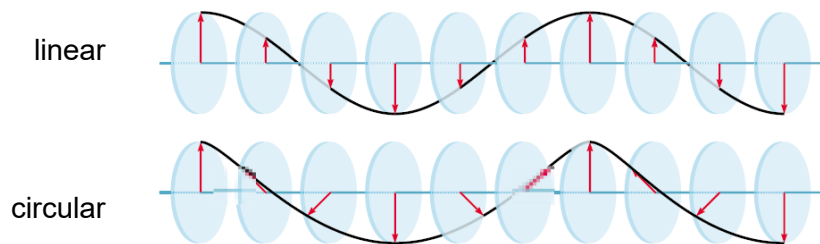

Circular polarized light oscillates only in one rotating direction

Polarization Types

Normal light oscillates in many directions

Linear polarized light oscillates only in one plane

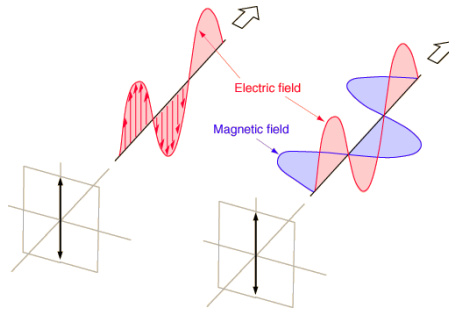

Polarization Types

Circularly polarized light consists of two perpendicular electromagnetic plane waves of equal amplitude and 90° difference in phase.

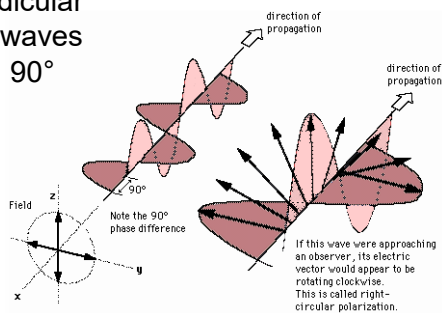

The oscillation direction of circular polarized light rotates

Achieving Circular Polarization

A quarter-wave plate divides linearly polarized light into two components polarized normally to each other and 90° out of phase.

This produces circularly polarized light.

http://en.wikipedia.org/wiki/Circular_polarizer#Circular_Polarizers

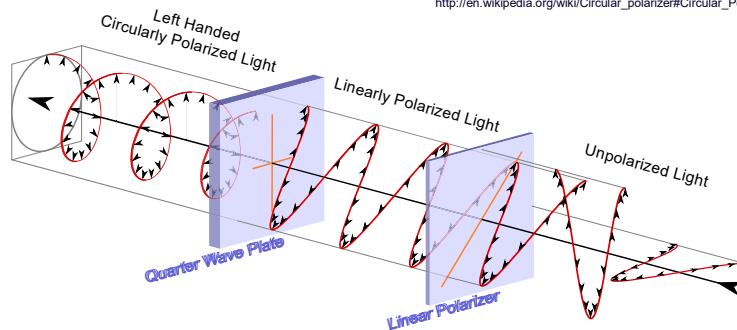

Polarization Types

linear polarization:

- orientation dependent
- works with all colors

circular polarization

- works in any orientation of the users head
- color dependent (phase shift filter)
- costs more

Infitec™ Stereo

Spectrum Multiplex:

Advantages:

- orientation independent
- screen independent
- high(er) contrast even in daylight

Disadvantages:

- color distortion
- crosstalk

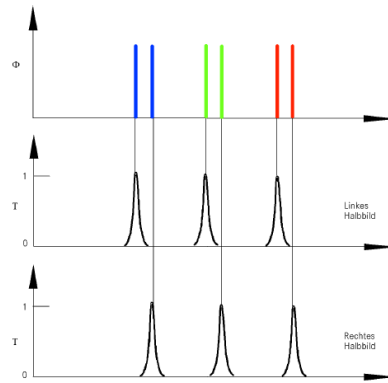

Infitec™ Stereo

uncalibrated

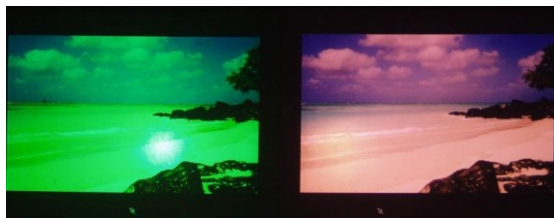

calibrated



Holographic Projection

Holographic Backprojection by Holografika Ltd. (www.holografika.com)

- No glasses needed, the 3D image can be seen with unassisted naked eye
- Viewers can walk around the screen in a wide field of view seeing the objects and shadows moving continuously as in the normal perspective. It is even possible to look behind the objects, hidden details appear, while others disappear (motion parallax)
- Unlimited number of viewers can see simultaneously the same 3D scene on the screen, with the possibility of seeing different details
- Objects appear behind or even in front of the screen like on holograms
- No positioning or head tracking applied
- Spatial points are addressed individually

Holographic Projection

pixels on screen send different light in different direction, thereby simulating light emanating from points in space:

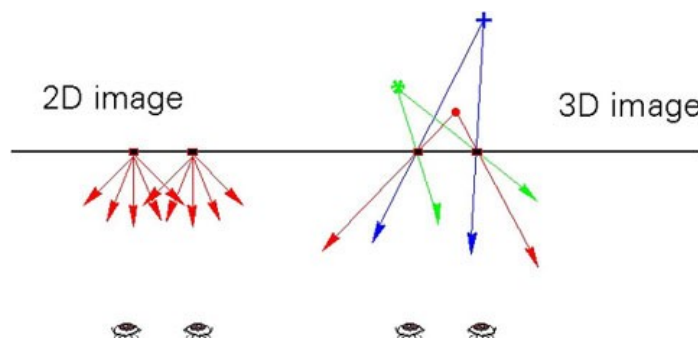

Holographic Projection

pixels on screen send different light in different direction, thereby simulating light emanating from points in space:



Anton L. Fuhrmann
2019

Advanced Topics in VR

